

ALERION 41
Specifications and Model Description
(Confidential)
March, 2011

PRINCIPAL DIMENSIONS

LENGTH OVERALL	40' - 6"
DESIGN WATERLINE LENGTH	30' - 6"
BEAM	11' - 2"
DRAFT	5' - 11"
DISPLACEMENT	14,500 lbs
BALLAST	6,000 lbs
SAIL AREA	875 ft ²
SAIL AREA / DISPL. RATIO	23.5

PEARSON
MARINE GROUP, Inc.
RT. 136 MARKET ST. WARREN, R.I. 02885-0328
TEL. (401) 247-3000 FAX (401) 247-4014

TITLE				SAIL PLAN			
FOR				ALERION 41			
DRAWN BY	DATE	CHECKED BY	DATE	DRAWN BY	DATE	CHECKED BY	DATE
MS	February 14, 2011						
SCALE	1/4" = 1'-0" (1-88)	DWG. NO.	200-307	REV.	B.		

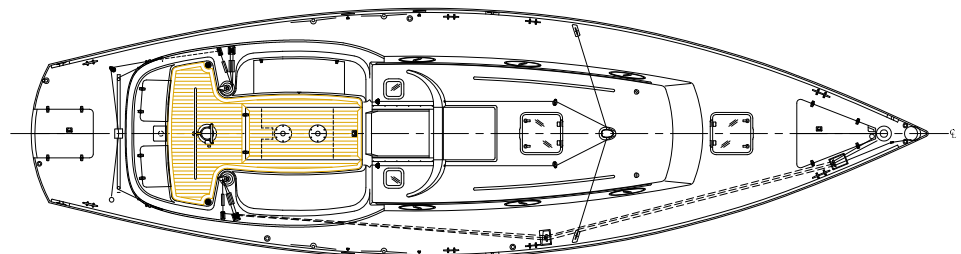
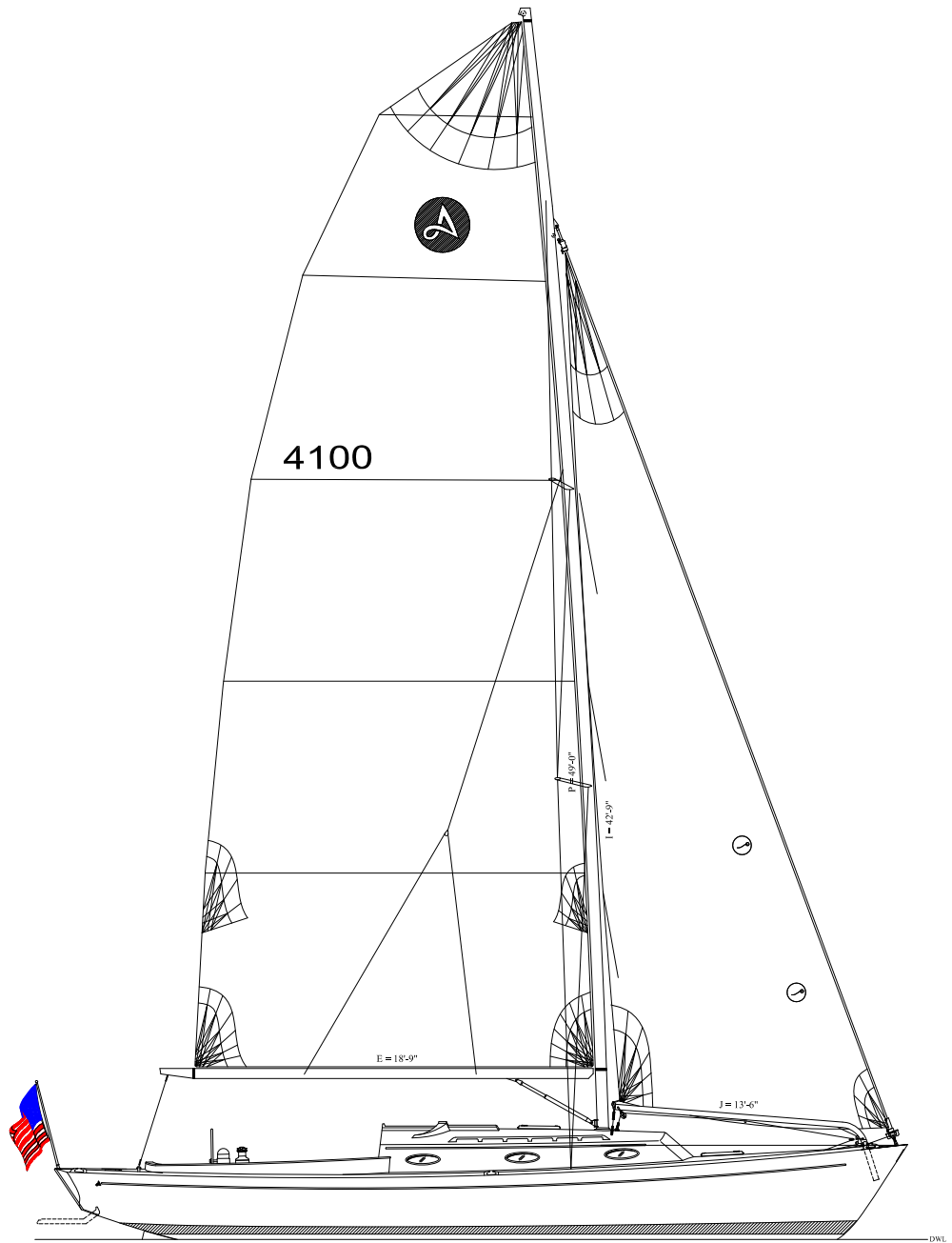
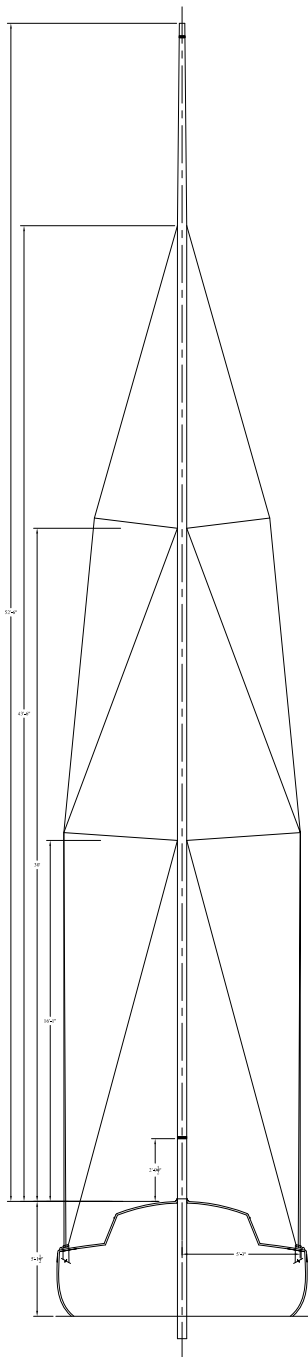

MATTHEW SMITH
NAVAL ARCHITECT

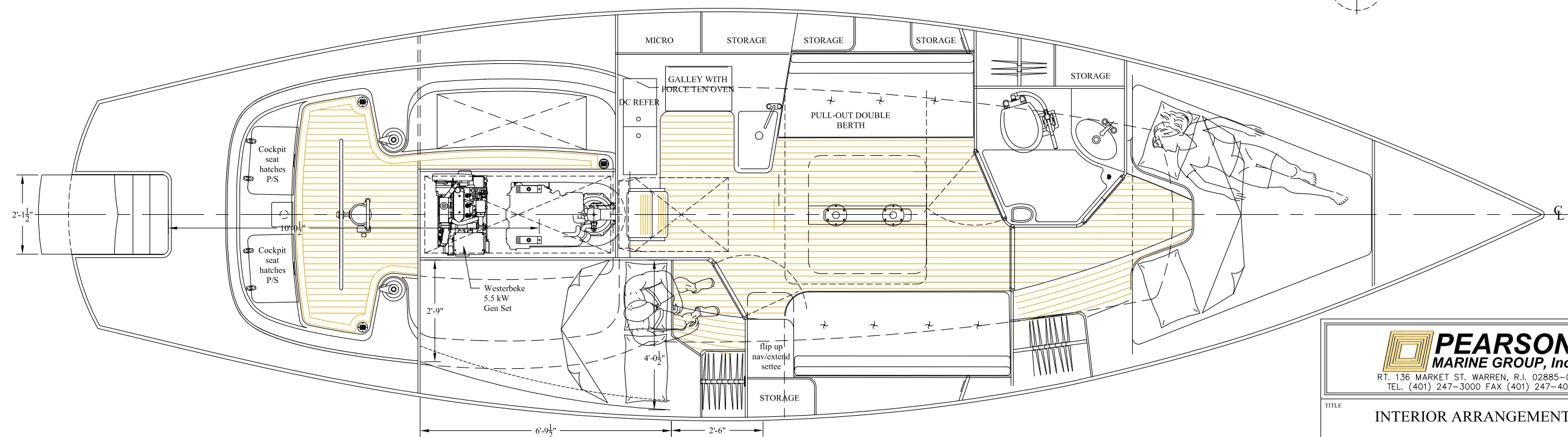
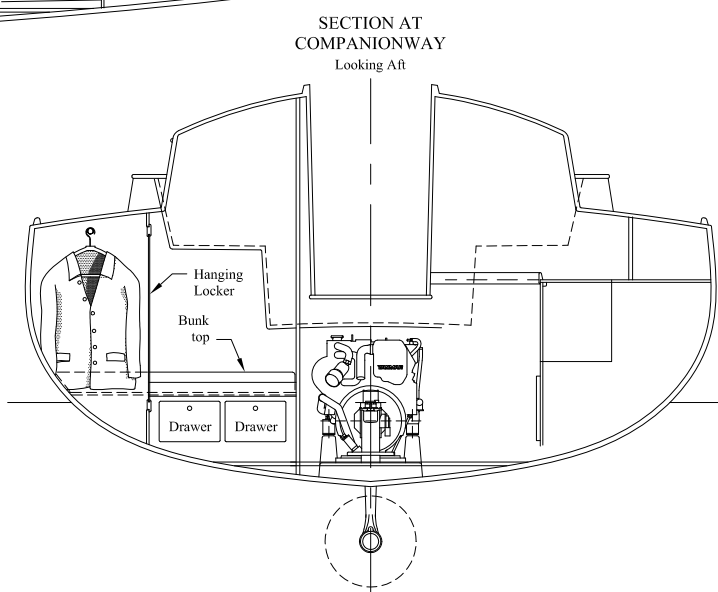
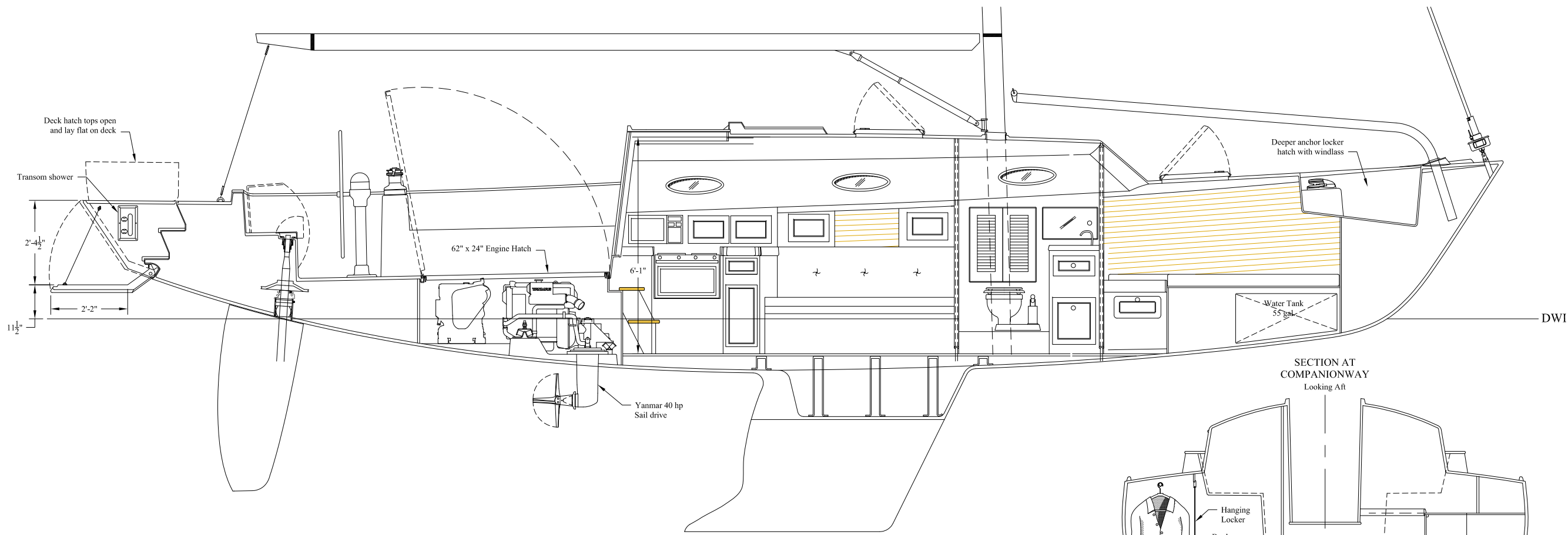

PEARSON
MARINE GROUP, Inc.
RT. 136 MARKET ST. WARREN, R.I. 02885-0328
TEL. (401) 247-3000 FAX (401) 247-4014

TITLE INTERIOR ARRANGEMENT (A)			
FOR ALERION 41			
DRAWN BY MS	DATE February 14, 2011	CHECKED BY	DATE
SCALE 1/2" = 1'-0" (1:24)	DWG. NO. 200-201	REV 0.	

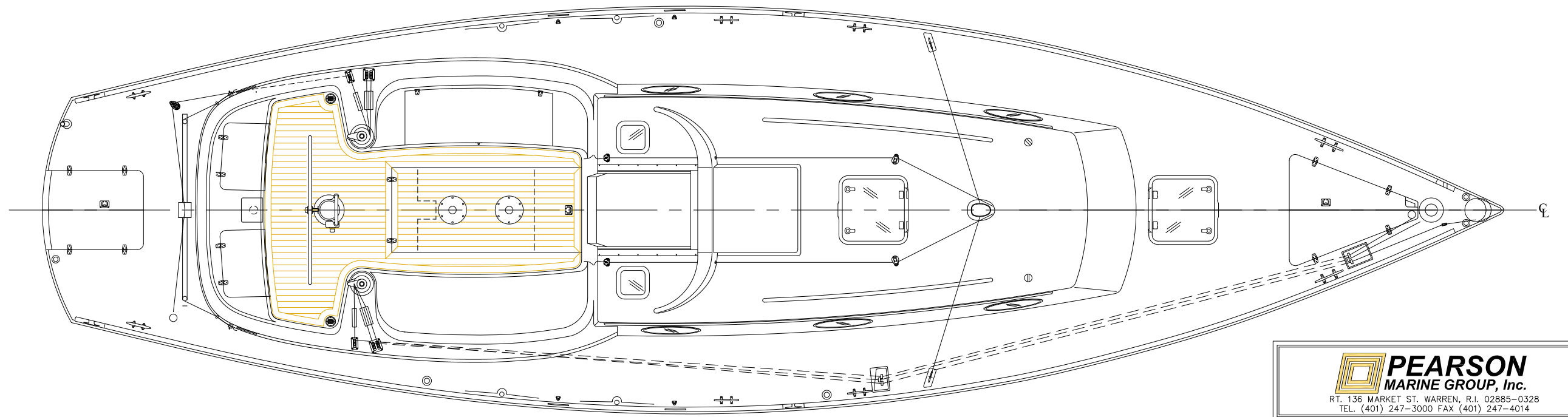
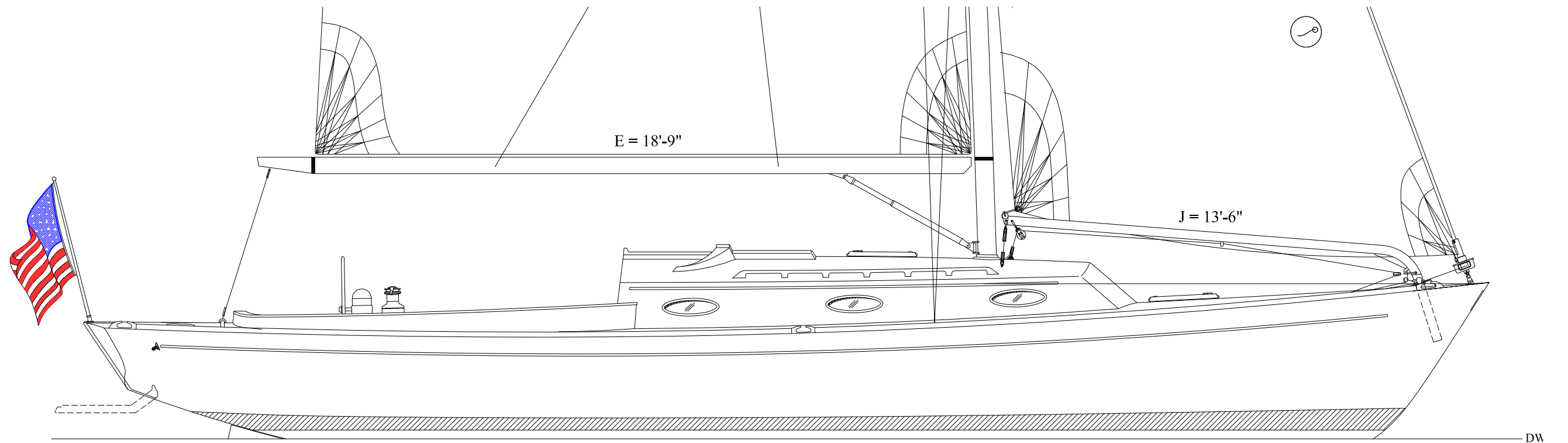

RT. 136 MARKET ST. WARREN, R.I. 02885-0328
 TEL. (401) 247-3000 FAX (401) 247-4014

TITLE			
INTERIOR ARRANGEMENT (A)			
FOR			
ALERION 41			
DRAWN BY	DATE	CHECKED BY	DATE
MS	February 14, 2011		
SCALE	1/2" = 1'-0" (1:24)	DWG. NO.	REV
		200-201	0.



Designer's Notes

The exciting new Alerion 41 is currently under development by Pearson Marine Group's talented staff of designers and engineers. For those who want their Alerion Sailing to extend past the hour or afternoon experienced on the Express or Sport series, the new "Alerion" Series of sailboats have standing headroom and accommodate multiple couples for extended cruising. The design brief for the stunning new Alerion 41 has been clearly defined from the outset.

- Maintain strong family resemblance and performance heritage of the AE33 and AE38.
- Maintain the philosophy of single-handed ease of sailing that the Alerion brand is known for.
- Provide a two-state room interior suitable for extended coastal cruising.
- Provide the purchaser with endless sailing enjoyment and stress free ownership.

The profile shows the natural development from the 33 and 38 with an elegant sheer, low coach roof, and elliptical port lights (to be opening in this model). The bow and stern profiles use the same geometry and family of curves that are derived from the very DNA of Alerion-Express and Alerion Sport.

The cockpit is the heart and soul of the 41; maintaining the format of her smaller sisters with comfortable settees port and starboard and command center aft. However, the A41 has room for a pedestal table and winch islands that accommodate reversible self-tailing electric winches. A removable coaming bolster provides added comfort for the captain while under way.

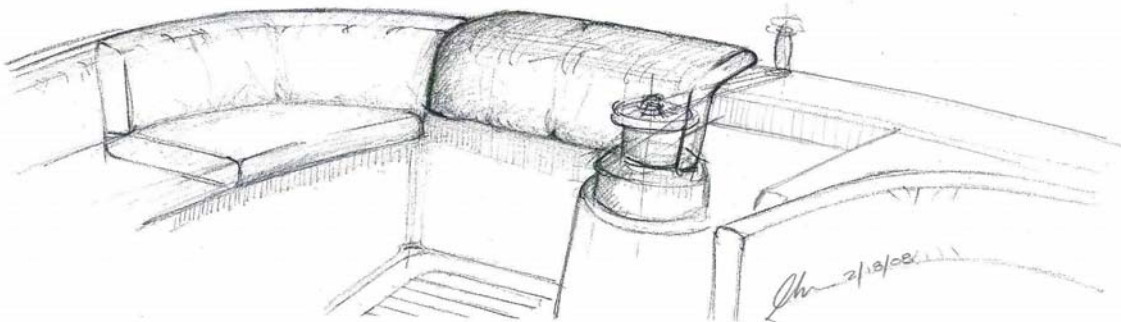

Removable Helm Coaming Bolster

Aft, the helmsperson can feel every nuance of the pulse of this thoroughbred through the pedestal mounted steering wheel. We've carefully designed this yacht to create the same spirited sailing experience that all Alerions are known for. Light displacement and a performance rig provide sailing characteristics unrivaled by any other boat in this class. Control of all the sailing functions is close at hand making this yacht easy to operate and a joy to sail. The A41 is a whole new era in Alerion Sailing.



The clean deck layout afforded by under deck control lines has allowed our design team to add such innovative features as a removable anchor chute and hidden anchor windlass. The water access system (see rendering) enables the transom to be converted to a marvelous boarding area either for swimming or disembarking from a tender. The convertibility of the water access feature allows the clean lines of the hull to be unspoiled while underway or at anchor.



Below decks the Alerion 41's interior is second to none. The hand-finished paneled bulkheads and doors are masterpieces of modern yacht construction with more than an acknowledging nod to the days of Vanderbilt and Sopwith. The bespoke interior can be finished in the owner's choice of exotic teak or a combination of wood furniture and white bulkheads.



The main cabin features wonderfully comfortable settee berths with the port side pulling out to form a double berth when needed. The spacious lockers outboard of the settees are accessed via beautifully crafted, solid wood, raised panel doors.

With modern navigation at the ready, the formal chart table has been superseded by a multifunction drop down desk large enough for a lap top computer. Outboard of the desk is the back-lit main electrical panel mounted in a locker face. There is plenty of space forward of the panel to add the additional electronics that are desired.

The galley provides all the necessities for onboard meal preparation and storage. Hot and cold pressure water, deep stainless steel sink, vacuum panel insulated refrigerated ice box, LPG stove with



an oven as well as a microwave are just a few of the standard features on the A41. Storage abounds inside the u-shaped galley and in the outboard lockers. As with everything in life you might have a specific need that requires a customized solution. Alerion Yachts is always prepared to work with you to customize the A41 to suit your needs.

Aft is the entry door to a second sleeping cabin that provides privacy not always found on other yachts of this size and displacement. This light airy cabin can be a haven for those wanting to grab a quick nap or an extended stay. A hanging locker and drawers provide ample storage while overhead and cockpit hatches provide plenty of fresh sea breeze.

The forward head compartment features an ample shower area and electric head. Light and ventilation are provided by an overhead Lewmar hatch and a stainless steel opening port in the house side. A Corian vanity and sink in owner's choice of color is complimented by raised-panel storage cabinets and a hanging locker. There is a second entry to the head from the master stateroom.



Completing the interior ensemble is the spacious forward master cabin. Plenty of storage in the hanging locker and bureau make an extended stay on the A41 easy.

The forward cabin has plenty of ventilation and equal amount of privacy. The oversized v-berth with a filler panel is larger than most berths in other yachts of this size. LED reading lights and optional storage shelves are just a few of the details that make this space perfect for the cruising couple.

For those that appreciate a boat with classic aesthetics, uncompromising performance, and cruising luxury will find the Alerion 41 in a class by itself. The Alerion 41 is a true "sailor's sailboat"; the enormous cockpit, carbon fiber mast and easy sail handling controls are optimized for Alerion Sailing. Daysail *and* cruise on your own terms with the ability to sail well in all conditions without the need to bring crew. We look forward to continuing a dialogue with you about this exceptional yacht.



Construction:

- Hull and Deck: SCRIMP® Infusion molded GRP Balsa / PVC foam core composite sandwich with selective carbon reinforcements. ISO-NPG gelcoat with vinylester resin barrier layer.
- Interior Structure: Pearson Composites Integrid® integrally infused floor structure and keel support system incorporating mast step and engine foundations. Primary transverse structural bulkheads infusion molded composite sandwich.
- Hull Exterior: Linear Poly Urethane topsides, recessed cove line and single boot stripe. All colors are owner's choice from standard chart.
- Bottom Paint: 3 coats. Color is owner's choice.
- Keel: One piece cast lead fin with bulb style
Keel is through bolted to molded hull sump with 316 SS bolts
Fin is faired to hull with seam over laminated with biaxial glass.
Keel finished with Interprotect epoxy barrier coat.
- Rudder: High Aspect Ratio carbon blade with Stainless Steel shaft.
Shaft fitted with bearing sleeves and emergency tiller attachment.

Spars and Rigging:

- Mast: Pre-preg carbon fiber Autoclave cured. Aluminum spreaders
Finished in LPU. G-10 mast step. Carbon gooseneck tangs. Antal luff track. Builder Hall Spars.
- Boom: Aluminum with quick cover handling system. 2 single line reef with option for third.
Optional Leisurefurl system.
Optional Hall Vboom.
- Jib Boom: Composite Jib Boom®. Clew outhaul and sheet are led aft under deck to starboard side cockpit mounted Harken "Rewind" electric winch.
Light air extender system.
- Jib Furler: Below deck Harken Mk IV Unit 2 manual furler with furling line lead aft under deck to starboard cockpit winch.
- Standing Rigging: Stainless Steel Rod.



Running Rigging:	Spectra, Vectran, Dacron.
Sails:	North Norlam. Camber stripes, tell tails, Alerion Logo and Sail Number. Main has double reef attachments Jib has vertical battens and overlaps mast to spreaders. Optional light air cruising gennaker mounted on removable prod.
Blocks:	Lewmar, Harken, as application dictates.
Winches:	Harken "Rewind" self-tailing electric winches (2 each) mounted port and starboard in cockpit on island forward of helm position. Controls mounted on cockpit faces aft of winches accessible to helms person.
Boom vang:	Quick Vang by Hall. Control line on Cabin top.
Mainsheet Traveler:	8:1 system lead to helm area.
Anchor windlass:	Lewmar or similar gypsy only.
Anchor and Rode:	Removable stainless steel bow roller.
Deck Hardware:	Custom mooring chocks, 2 aft, 4 amidships, 2 forward. Herreshoff style stainless steel mooring cleats.
Steering:	Lewmar system. "Reliant" pedestal mounted in cockpit, stainless steel destroyer wheel with varnished teak or leather covered rim. Integral shaft brake. Stainless steel guard with instrument pod. Side mounted single lever engine control on starboard side. Rudder shaft mounted radial drive with wire / chain / connection to steerer. Vectran (or equivalent) strop type stop lanyard attached to radial drive and anchored to hull structure.
Cockpit:	Symmetrical Alerion cockpit with helm area aft, settees forward and removable table. Port settee has hatch for access to below deck locker. Cockpit is self-draining to IMO standards and surfaced in teak. Winch islands located port and starboard forward of helm area with primary winches recessed into islands (AE33). Winch islands have rope tail bins below.



	<p>Engine panel, winch switches, and manual bilge pump mounted in helm area.</p> <p>Emergency tiller and upper rudder bearing access plate in surface of helm seat.</p>
Stern:	<p>Counter stern with teak taffrail, and water access system.</p> <p>Radar mast mounted to port.</p>
Deck-Hull Joint:	<p>Methacrylate adhesive bonded lapped flange type with varnished teak toerail.</p> <p>Toerail has a minimum height of 1.25" on the inboard face.</p> <p>Varnished teak taffrail at transom.</p> <p>Bow and stern chocks cap ends of toerail.</p> <p>Amidships chocks (4) are set in integrally with toerail. Chocks fitted with stainless steel chafe guards at hull edge.</p> <p>Chocks are chrome-plated cast bronze.</p> <p>"Sling" here plaques mounted 2 each port and starboard.</p>
Lifelines (Optional)	<p>Stainless steel tapered stanchions with through bolted bases.</p> <p>Lifelines are 1x19 sswr.</p> <p>Gates are located port and starboard amidships.</p> <p>Pulpits and stanchions are 316 tubing 25mm Ø .</p> <p>Upper lifeline is 24" above the deck edge.</p>
Deck Skylights:	<p>Lewmar high-polish finish aluminum.</p> <p>Locations: Aft Cabin (cockpit mounted, deck mounted), Toilet Compartment, Forward Cabin foredeck.</p> <p>Size 54 (3) Location: Forward Cabin Coachroof, Centerline in Main Cabin.</p>
Coachroof Ports:	<p>Alerion custom stainless steel, (6) total, opening. (1) starboard in cockpit face for aft cabin.</p>
Companionway:	<p>Pearson standard with acrylic drop boards, Top mounted GRP slider and seahood.</p> <p>Companionway opening is framed in varnished teak.</p> <p>Stowage rack provided for drop boards in port cockpit locker.</p> <p>Hasp and combination lock provided to secure companionway.</p>
Dodger (optional) :	<p>Thurston; Sunbrella with stainless steel bows.</p> <p>Sunbrella color is owner's choice from standard range.</p> <p>Removable side panels.</p>



Interior:

- Joinery: Owners choice of Cherry, Teak or traditional Herreshoff style joinery. Trim is epoxy laminated cold molded veneer and solid lumber. Joinery is finished in varnish with satin sheen and high gloss accents.
- Locker Doors: Solid lumber raised panel doors with push button positive latches.
- Hull Ceilings: Ceiling to match interior joinery selection.
Ceiling installed on hull sides in forward and main cabins.
- Overhead
(Underside of deck): Vinyl panel headliner with varnished wood accents strips between panels.
Panels are removable for access to underside of composite deck.
- Galley and Head
Compartment
Counters: Hi-Macs or similar in owners choice of color from standard range.
- Cabin Sole: Teak and Holly with plywood substrate. Underside is epoxy coated. Surface is varnish with satin sheen.
PVI quarter turn fasteners secure bilge access panels.
- Upholstery: Berths and Settee cushion cores from high-quality laminated upholstery foam. Fabric covers from Sunbrella with owner's choice of color from standard range.
- Window Treatments: Shades at ports (7).
Basic Skyscreens at underside of deck hatches.
- Head compartment: Molded GRP pan in Sport White gelcoat with non-skid sole. Vanity counter is Hi-Macs to match galley. Sink is Hi-Macs. Separate shower stall with circular enclosure.

Domestic Systems

- Fresh Water: Hot and Cold pressure water to galley, forward head, aft head shower and cockpit shower.
Single rotary-molded polyethylene tank.
- Potable Water: Galley has separate faucet from pressure cold water through charcoal filter.



- Toilet: Tecma "Silence" Head with holding tank.
Tank equipped with deck pump out and off shore overboard discharge.
- Stove: Force 10 two burner LPG with oven. Microwave.
Dedicated self-draining tank locker in aft deck.
Electric solenoid supply shut off control in Galley.
- Refrigeration: Top access Fridge compartment in galley counter with high-efficiency vacuum panel insulation.
Refrigeration system is 12 VDC electric hold over plate style.

Mechanical:

- Engine: Yanmar 40 hp.
- Propeller: Gori folding.
- Fuel Filtration: Racor with water separator.
- Fuel Tank: Custom Aluminum. 40 US gals.
- Exhaust Fan: High capacity, 4"Ø 12VDC in engine space.
- Bilge Pumps: Manual and electric with alarms.

Electrics

- Electrical System: 12 VDC/110VAC
- Shore Power: Shore Power receptacle in stern access area with galvanic isolator.
- Battery Charger: 50 Amp
- Inverter: 1500 watt
- Alternator: High Output, on engine.
- Batteries: Lifeline AGM. (2) 8D, (1) group 31 starting.
- Main Panel: Circuit breaker type with amp and voltage meters.
Panel legends are back lit.



Panel located outboard port side in Main Cabin.

Lighting: LED Overhead, bunk, low level and courtesy lights.

Exterior Lights: LED Navigation, foredeck flood and cockpit courtesy lights.

Equipment.

Mooring: Fenders (4) and Docklines (4).

Shore Power: 50ft. 120VAC shore power cable.